

材質	處理	硬度
SUJ2	高週波	HRC60~64

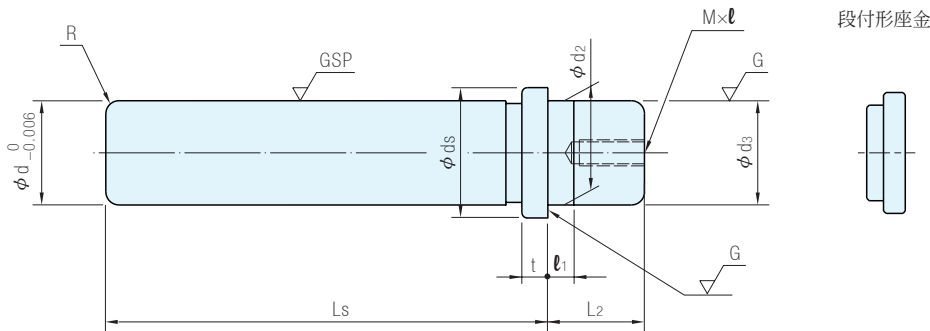

品號		d2	d3	dS	L2	M×ℓ	t	R	ℓ1	附屬螺絲
TYPE	d									
DPO	19	-0.018 -0.022	-0.04 -0.06	29	23	M 6×15	5	3	7	M 6×20
	20			32						
	22			27	6		4			
	23							35		
	24							38		
	25			32	8		8	8		
	27					44				
	28					48				
	31					50			M 8×30	
	32			37	10	5	10	M10×30		
	36								54	
	37								59	
	38								66	
	40								72	
45										
50										
56										

Wa. 注意

- 精度標準請參閱脫料板・導柱・導套單元FUTABA導柱導套的精度基準
- 此產品是日本進口，缺貨時交期較久，請儘可能提前4週訂貨

Ps. 備註

- 模座導柱專用之有機鉍強力潤滑劑請參閱化學產品單元S-00668

DWD段付形座金
加工尺寸

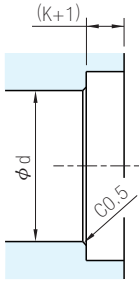

DWD段付形座金

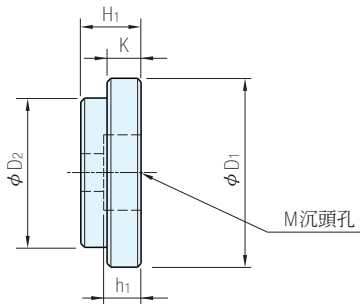

d	稱呼	D ₁	D ₂	K	H ₁	h ₁		
19	19	26	18.5	5	9	6		
20		30	21.5					
22	22	32	23.5					
23		35	26.5					
24	24	40	30.5		7		13	8
25		48	36.5					
27	27	50	39.5	9		16	10	
28		55	44.5					
31	31	60	49.5					
32		65	55.5					
36	36							
37								
38	37							
40								
45	45							
50								
56	56							

品 號		Ls																				
TYPE	d	75	80	85	90	95	100	105	110	115	120	125	130	135	140	145	150	155	160	165	170	
DPO	19	•		•		•		•		•		•		•								
	20	•		•		•		•		•		•		•								
	22				•	•	•	•	•	•	•	•	•	•	•		•		•			
	23				•		•		•		•		•		•		•		•			
	24					•		•		•		•		•		•		•		•		
	25					•	•	•	•	•	•	•	•	•	•	•	•	•	•	•	•	
	27						•		•		•		•		•		•		•		•	
	28							•		•		•		•		•		•		•		
	31								•		•		•		•		•		•		•	
	32								•	•	•	•	•	•	•	•	•	•	•	•	•	•
36									•		•		•		•		•		•		•	

品 號		Ls																			
TYPE	d	120	125	130	135	140	145	150	155	160	165	170	175	180	185	190	195	200	205	210	
DPO	37	•		•		•		•		•		•		•		•		•		•	
	38	•		•		•		•		•		•		•		•		•		•	
	40	•	•		•		•		•		•		•		•		•		•		•
	45	•	•		•		•		•		•		•		•		•		•		•
	50						•	•	•	•	•	•	•	•	•	•	•	•	•	•	•
	56							•	•	•	•	•	•	•	•	•	•	•	•	•	•

訂貨： × 交期： 天 d=20.22.24.25
 天 其它 28.32.36.38

DP019 × 75